

REMOVABLE WATERTIGHT
INSPECTION PORTS, 10" OPENING

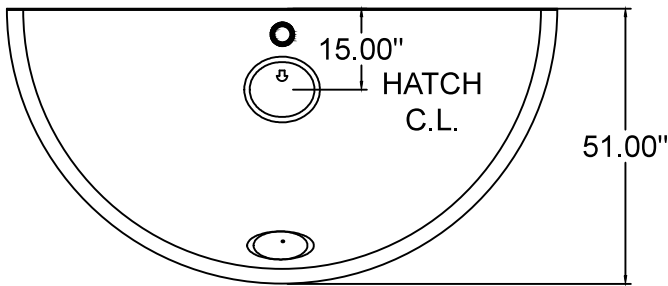
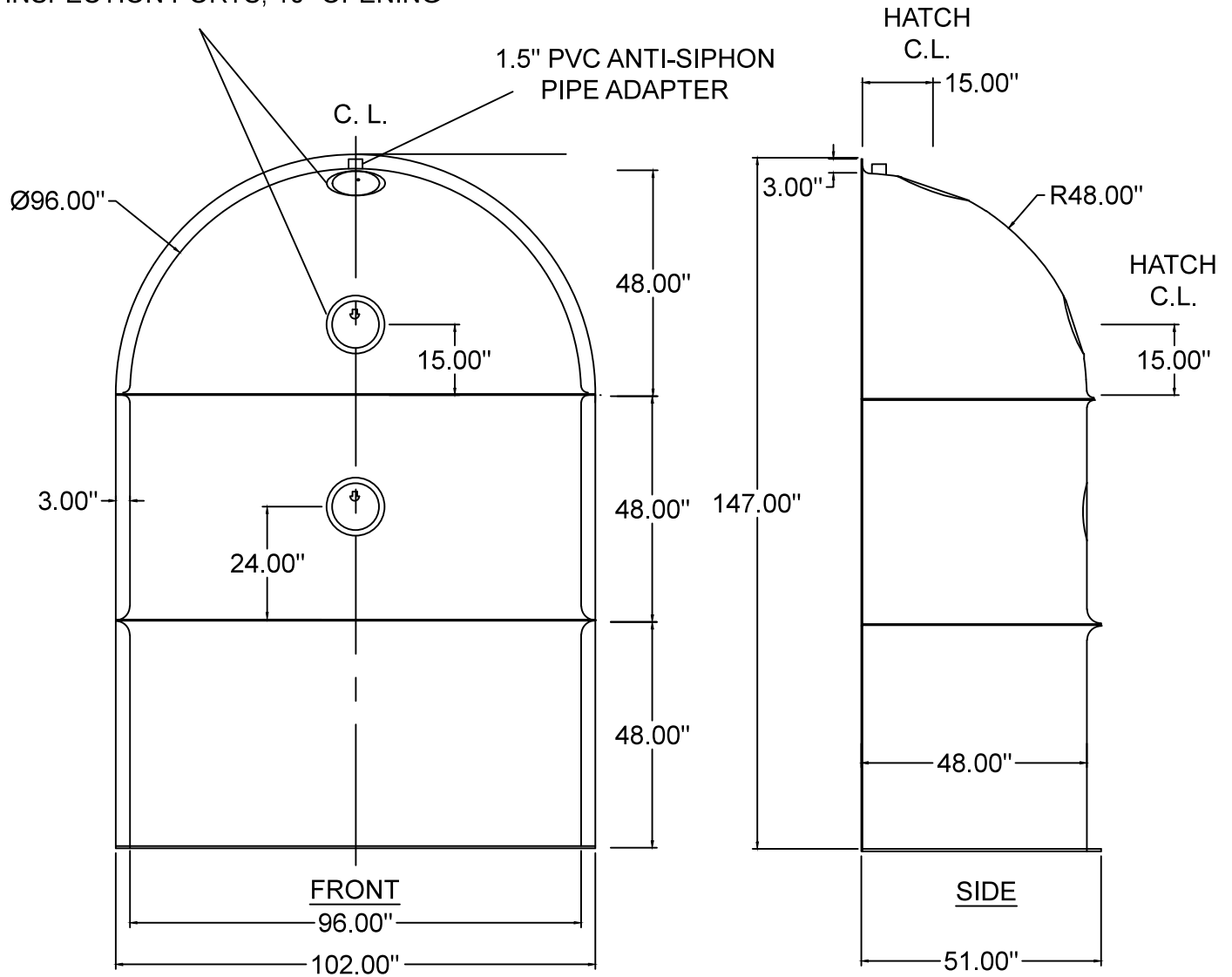

PLAN

HEAVY DUTY SNOOT WITH
1708 BIAXIAL FIBERGLASS
REINFORCEMENT

U.S. PATENT #6126817 ADDITIONAL PATENTS PENDING

BMP, INC

53 MT. ARCHER RD., LYME CT 06371
(800) 504-8008 FAX: (860) 434-3195

DESCRIPTION 96FTBB HD SNOOT OIL & DEBRIS STOP (TOP & 2 BASES)	DATE 07/29/15	SCALE NONE
	DRAWING NUMBER 96FTBB HD	