

OUTLET STRUCTURE WITH FLOW CONTROL AND OVERFLOW POLLUTION RETENTION

SYSTEM ADVANTAGES:

FLOW DISCHARGE RATE CONTROLLED WITHOUT CLOGGING OF ORIFICE

OVERFLOW MODE STILL CONTAINS FLOATING POLLUTANTS

STORMWATER QUALITY AND QUANTITY CONTROL IN ONE SIMPLE, EASY TO MAINTAIN STRUCTURE

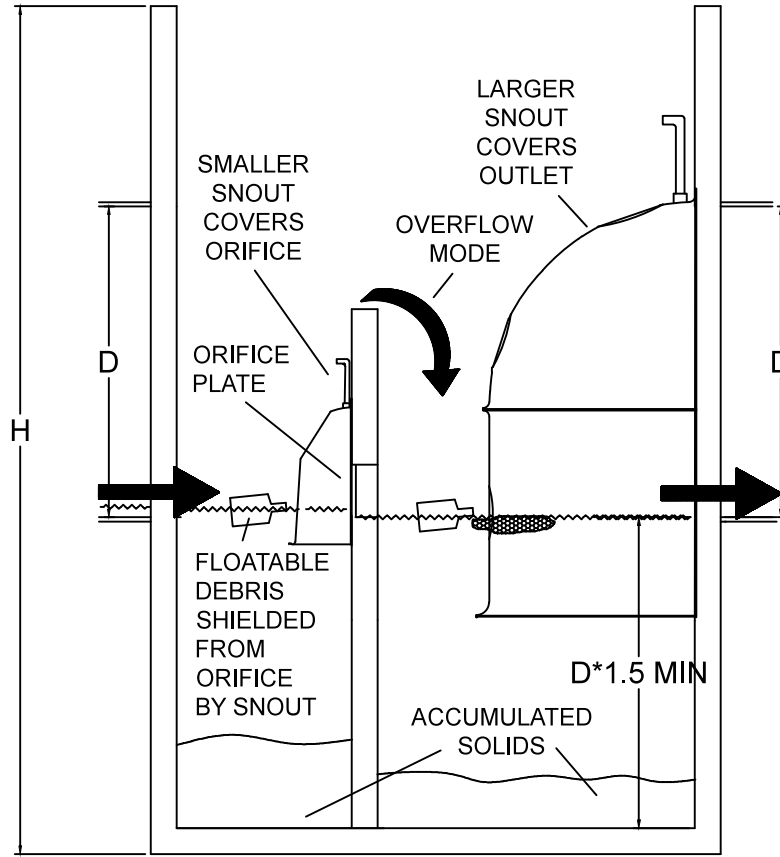

INFLOW FROM POND OR STORMWATER DETENTION FACILITY

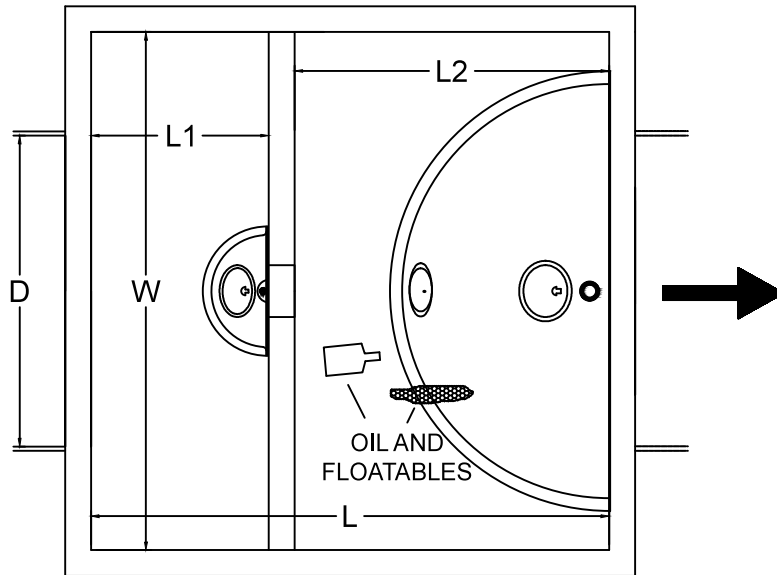

DIMENSIONS:

- D= PIPE DIAMETER
- H= HEIGHT OVER ALL
- L= LENGTH INSIDE
- L1= LENGTH TO PARTITION
- L2= LENGTH TO BACK WALL
- W= WIDTH INSIDE

SNOUT U.S. PATENT # 6126817 ADDITIONAL PATENTS PENDING

<p>BMP, INC. 53 MT. ARCHER RD. LYME, CT 06371 800-504-8008 WWW.BESTMP.COM</p>		
<p>DESCRIPTION OUTLET STRUCTURE WITH OVERFLOW</p>	<p>DATE 02/05/01</p>	<p>SCALE N.T.S.</p>
<p>DRAWING NUMBER DC-00</p>		